

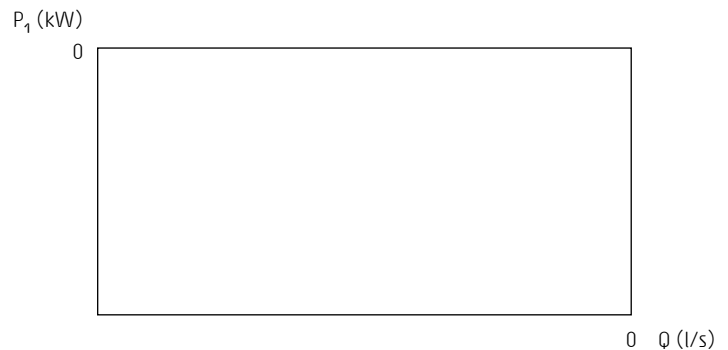

Bravo 20

Electrical submersible slurry pump

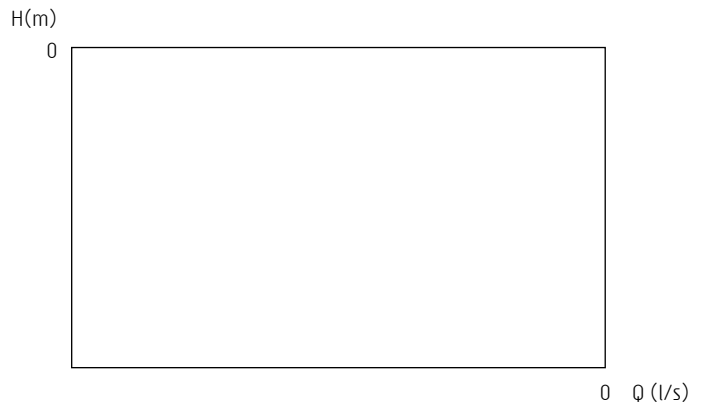
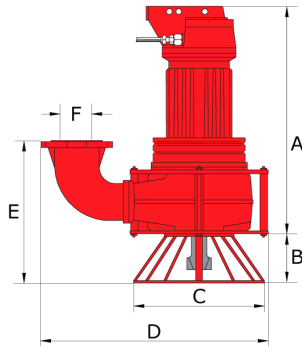

50 Hz	Bravo 20
Discharge connection F	4"
Rated power P ₂ [kW]	3,5
Max. power consumption P ₁ [kW]	4,4
Shaft speed [r.p.m.]	1450
Rated current at 230V	15,9 A
Rated current at 400V	8,8 A
Rated current at 500V	7,0 A
Solids passage with/ without agitator	30 / 80 mm
Dimensions A / B / C / D / E	700 / 150 / 410 / 713 / 447 mm
Weight	162 kg
<i>Other voltages on request</i>	

ISO 9906/A

General description

Vortex impeller pump with agitator in wear resistant NiHard 4 for reliable transport of highly abrasive solids in high concentrations. For industry, mining, construction works, dredging and other demanding applications

Classification

Electrical submersible slurry pump
Protection class: IP 68

Electrical motor

Squirrel cage induction motor
Insulation class: H (IEC 85)

Motor protection

Thermoswitches in motor windings

This pump must be used with external motor protection in accordance with technical data

Cable - SubCab 20 m (66 ft)

50 Hz 230 - 500V: 1x7x2.5mm²
60 Hz 230V: 1xAWG12/4 + 1xAWG14/4
60 Hz 380 - 575V: 1xAWG12/4 + 1xAWG14/4

Shaft seals

Double mechanical shaft seals running in an oil compartment
Material lower seal: silicon carbide - silicon carbide
Material upper seal: carbon - ceramic

Materials

Motor housing: *Cast iron*
Wear plate: *NiHard 4*
Pump housing: *NiHard 4*
Flange discharge connection: *NiHard 4*
Hose or Iso-G BSP adapter: *Cast iron*
Impeller: *NiHard 4*
Agitator: *NiHard 4*
Shaft: *Stainless steel*
Bolts: *Stainless steel*
Electrical cable: *Neoprene*
Primer: *Alkyd primer*
Top coating: *Two component high-build polyurethane coating*

Limitations

Max. submersion depth: 20 m (66 ft)
Max. liquid temperature: 40 °C (104 °F)
Allowed pH range: 4 - 10

Specifications can be changed without notice